

Flexible Fixture Hangers, EXJF Couplings, ESD and ESS Swivels

Explosionproof, Dust-Ignitionproof

UNILETS® for use with Threaded Metal Conduit. For Use with Rigid Fixture Hangers Where Fixture Stem is More Than 304.8 mm (12") Long.

NEC/CEC:

Class I, Division 1 and 2, Groups A, B, C, D

Class II, Division 1 and 2, Groups E, F, G

Class III

Applications

- Fixture hangers and accessories for suspension of industrial type HID, incandescent, and fluorescent lighting fixtures in Class I, Class II, and Class III classified locations.
- Suitable for use in areas where moisture, dust and corrosive atmospheres are present.

Features

- EYJF Hanger Coupling
 - Meets NEC Sec. 501 requirement for flexible suspension where fixture stem is more than 304.8 mm (12 in) long.
 - Watertight construction.
 - Convenient method for attaching explosionproof lighting fixtures to non-flexible hangers.
 - Allows free swing of lighting fixture in any direction. Absorbs shock, prevents damage to conduit and connections.
 - Assures plumb hanging of fixture.
 - Both end fittings are female with removable male close nipples. To make union end-coupling, remove nipple from either end and thread in a 1/2" or 3/4" UNY Union.
 - Female end fittings have setscrews with screwdriver slot to allow locking of conduit. Prevents turning of fixture stem and nipple.
- ESS and ESD swivels for use with rigid fixture hangers where fixture stem is more than 304.8 mm (12 in) long.

Standard Materials

- EXJF flexible hanger couplings: outer bronze braid, inner brass core with insulating liner and brass end fittings.
- ESD and ESS swivels: malleable iron.

Standard Finishes

- EXJF flexible couplings: natural finish.
- ESD and ESS swivels: triple-coat – (1) zinc electroplate, (2) chromate, and (3) epoxy powder coat.

Options

- EXJF available in stainless steel, add **-SS** to catalog number.

NEC/CEC Certifications and Compliances

- UL Listed: E10444
- UL Standard: 1203
- CSA Certified: 065182



EXJF



ESD



ESS

Illustrated Features

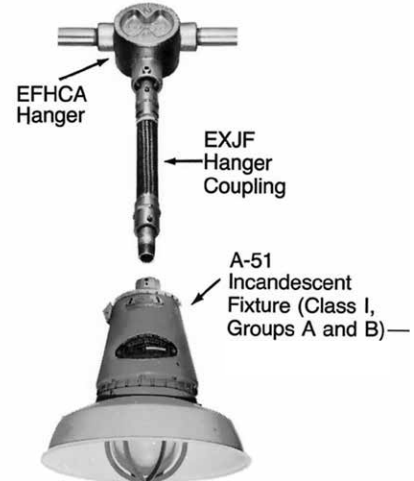

Flexible Fixture Hangers, EXJF Couplings, ESD and ESS Swivels

Explosionproof, Dust-Ignitionproof

UNILETS® for use with Threaded Metal Conduit. For Use with Rigid Fixture Hangers Where Fixture Stem is More Than 304.8 mm (12") Long.

NEC/CEC:

Class I, Division 1 and 2, Groups A, B♦, C, D

Class II, Division 1 and 2, Groups E, F, G

Class III

POLES/HANGERS: NEC/CEC EXPLOSIONPROOF FLEXIBLE FIXTURE HANGERS

	Size (Inches)	Millimeters (Inches)		Catalog Number
		Flexible Length	Overall Length	

EXJF Flexible Fixture Hanger ①



Raintight construction. Supplied with two female hubs, each with a removable close nipple. Can be used to make male to male, female to male or female to female. Setscrew with screwdriver slot allows locking of conduit—prevents fixture stem from turning. Maximum load 120 pounds.

1/2	102 (4.00)	276 (10.88)	EXJF14
3/4	102 (4.00)	278 (10.94)	EXJF24
1/2	152 (6.00)	327 (12.88)	EXJF16
3/4	152 (6.00)	329 (12.94)	EXJF26
1/2	203 (8.00)	329 (14.88)	EXJF18
3/4	203 (8.00)	379 (14.94)	EXJF28
1/2	254 (10.00)	429 (16.88)	EXJF110
3/4	254 (10.00)	430 (16.94)	EXJF210
1/2	305 (12.00)	480 (18.88)	EXJF112
3/4	305 (12.00)	481 (18.94)	EXJF212
1/2	381 (15.00)	556 (21.88)	EXJF115
3/4	381 (15.00)	557 (21.94)	EXJF215
1/2	457 (18.00)	632 (24.88)	EXJF118
3/4	457 (18.00)	633 (24.94)	EXJF218

Swivel Hangers — Setscrew with screwdriver slot allows locking of conduit — Prevents fixture stem from turning



ESD Swivel

15° swivel from center and full 360° free swing.

1/2	ESD50 ②
3/4	ESD75 ②



ESS Swivel

15° swivel from center.

1/2	ESS50 ②
3/4	ESS75 ②

① Available in stainless steel. Add suffix **-SS** to catalog number. Consult your local sales representative.

② Not CSA Certified.

♦ Shaded area indicates items suitable for Class I, Groups A and B in addition to Class I, Groups C and D; Class II, Groups E, F and G; and Class III.

Flexible Fixture Hangers, EXJF Couplings, ESD and ESS Swivel

Explosionproof, Dust-Ignitionproof

UNILETS® for use with Threaded Metal Conduit. For Use with Rigid Fixture Hangers Where Fixture Stem is More Than 304.8 mm (12") Long.

NEC/CEC:

Class I, Division 1 and 2, Groups A, B, C, D

Class II, Division 1 and 2, Groups E, F, G

Class III

Dimensions in Millimeters (Inches)

ESS Swivel

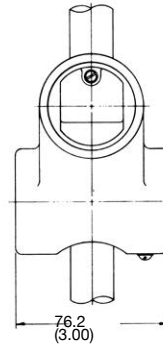
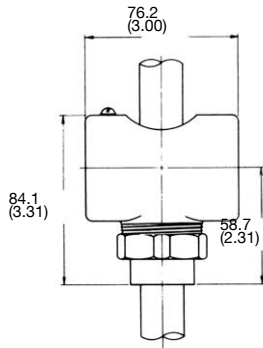

ESD Swivel

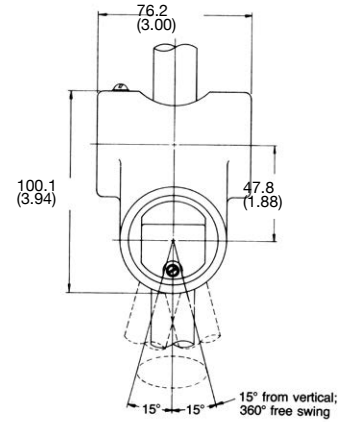

EXJF

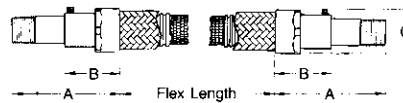

Size Inches	Dimensions in Millimeters (Inches)		
	A	B	C
1/2	85.9 (3.38)	47.8 (1.88)	36.6 (1.44)
3/4	85.9 (3.38)	47.8 (1.88)	44.5 (1.75)

POLES/HANGERS: NEC/CEC EXPLOSIONPROOF FLEXIBLE FIXTURE HANGERS

Appleton